

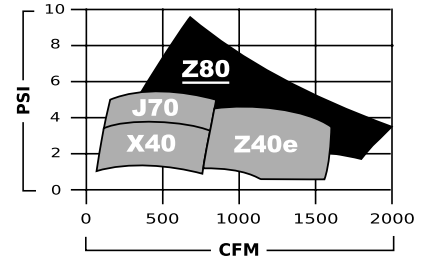

FLOWRATE:	400-2000 CFM
PRESSURE:	2-9 PSI, 50-250"WC
DRIVE SYSTEM:	BELT DRIVEN
MOTOR SIZES:	15-40 HP
SPINDLE RPM:	14,500 - 26,800

PEAK EFFICIENCY:	76%
MAX INLET TEMP:	120°F
DISCHARGE TEMP:	200°F MAX
INLET SIZE:	5" OD
OUTLET SIZE:	4" OD



COMPONENT SPECS:

1 HEAD UNIT

High-efficiency centrifugal compressor stage. Reaches peak efficiency of 76%. Housing and volute are A356-T6 aluminum; Impeller is investment cast aluminum.

2 DRIVE COVER

High-impact cross-linked polyethylene.

3 MOUNTING PLATE

Machined from A356-T6 aluminum.

4 MOTOR

STANDARD: TEFC, dual voltage (230/480) with 1.25 service factor.
OPTIONAL: Inverter duty, washdown or explosion proof.

5 MOUNTING RAILS

STANDARD: Rigid mounting rails
OPTIONAL: Vibration isolating mounting rails.

6 SPINDLE ASSEMBLY

Permanently lubricated, rigidly preloaded 4-bearing spindle.
SHAFT: Alloy Steel, Heat Treated; optional Stainless Steel.
BEARINGS: Ceramic Hybrid, ABEC 9
SEALS: High-performance PTFE lip seal for standard units; Controlled-gap labyrinth seal for high-speed units (23,000 RPM and higher)

7 BLOWER PULLEY

Machined from A356-T6 hard anodized aluminum.

8 DRIVE BELT

Micro-groove 14-rib belt.

9 TENSIONER

Dual-bearing backside automatic tensioner.

10 DRIVE PULLEY

Machined from billet stainless steel and balanced to ISO G4 tolerances.

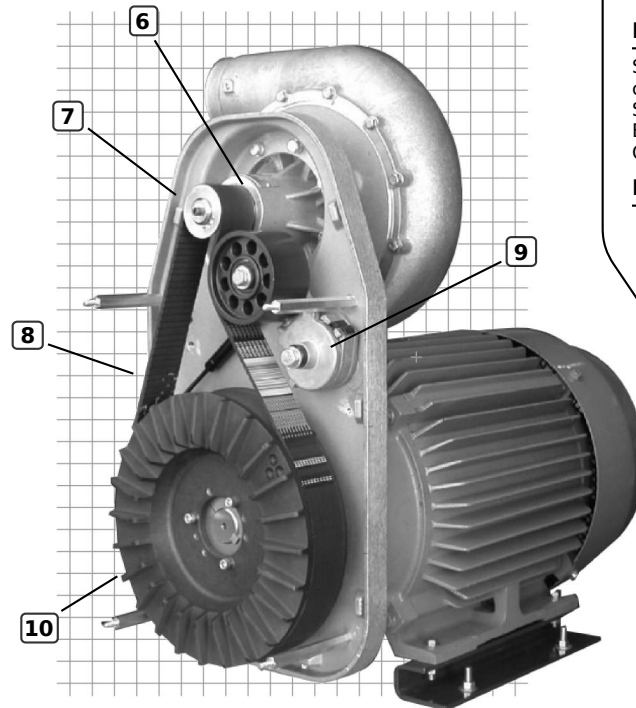
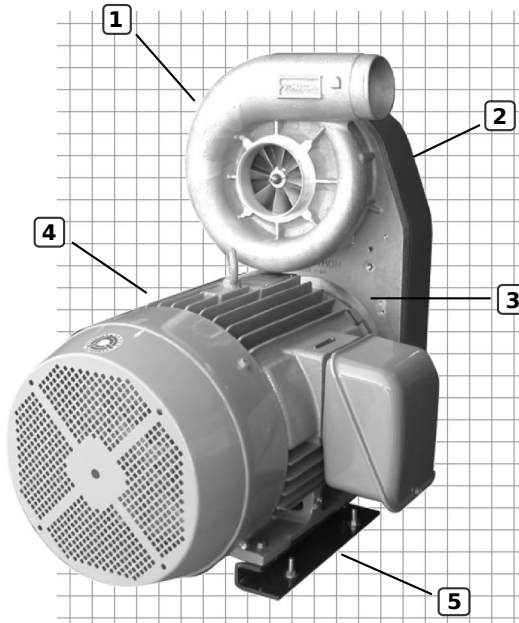

AIRPOWER FEATURES

Highest Performance

Outperforms any blower of equal motor size. Flow and Pressure not attainable with competitive single-stage products are easily achieved.

Best Durability

Spindle and drive system are cooled by patented Fresh-Aire® System. Belt life: 8,000 hrs. Bearing life: up to 80,000 hrs. Outlasts any equally-sized blower.

Highest Efficiency

Each model is aerodynamically optimized to attain the best efficiency possible. Nothing can match the performance of an AirPower blower at a lower energy cost.



Impeller: Optimized inducer blading with splitter, radial discharge.

PERFORMANCE MAPS

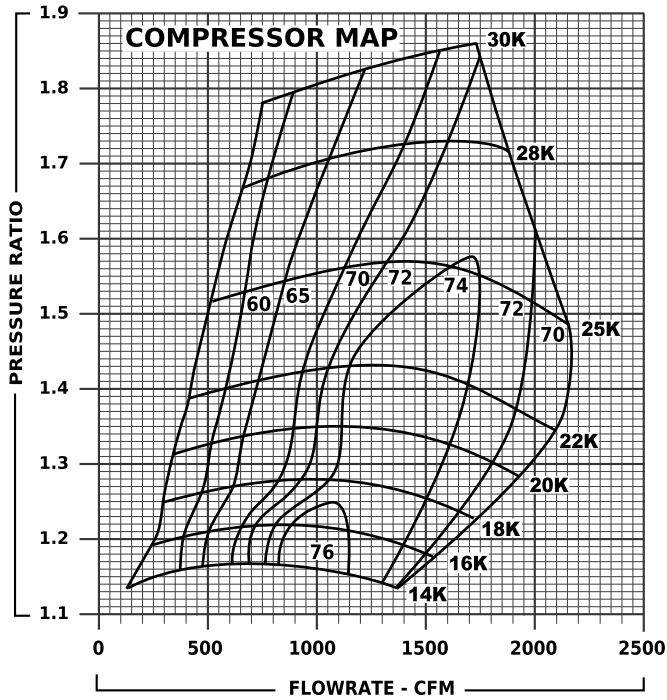

Data corrected to SAE Standard J-1723 (29.23 IN HgA, 527°R)

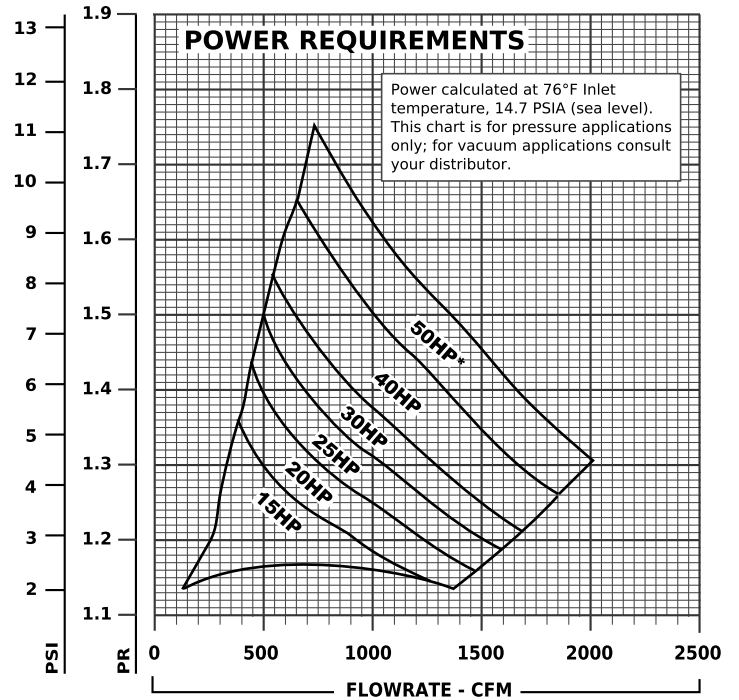

*50 HP Systems are currently unavailable.

DIMENSIONS

MOTOR SERIES	STANDARD MOUNTS			ISOLATION MOUNTS			AG	A	B	C	Wt(lbs)
	OAH	INLET	OUTLET	OAH	INLET	OUTLET					
254TC (15 HP)	29.805	21.75	27.695	30.3675	22-5/16	28.2575		4-7/8	12.5	8.5	
256TC (20 HP)	29.805	21.75	27.695	30.3675	22-5/16	28.2575		5.75	12.5	8.5	
284TC (25 HP)	31.425	23.37	29.315	31.425	23.37	29.315		6.25	11	8.5	
286TC (30, 40 HP)	31.425	23.37	29.315	31.425	23.37	29.315		6.25	11	8.5	

